



Solar Water Heating: A Question & Answer Primer

Authors

Block, David
Harrison, John

Publication Number

FSEC-EN-5-83

Copyright

Copyright © Florida Solar Energy Center/University of Central Florida
1679 Clearlake Road, Cocoa, Florida 32922, USA
(321) 638-1000
All rights reserved.

Disclaimer

The Florida Solar Energy Center/University of Central Florida nor any agency thereof, nor any of their employees, makes any warranty, express or implied, or assumes any legal liability or responsibility for the accuracy, completeness, or usefulness of any information, apparatus, product, or process disclosed, or represents that its use would not infringe privately owned rights. Reference herein to any specific commercial product, process, or service by trade name, trademark, manufacturer, or otherwise does not necessarily constitute or imply its endorsement, recommendation, or favoring by the Florida Solar Energy Center/University of Central Florida or any agency thereof. The views and opinions of authors expressed herein do not necessarily state or reflect those of the Florida Solar Energy Center/University of Central Florida or any agency thereof.

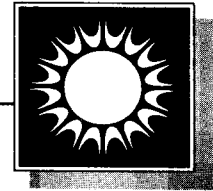

Solar water heating

A question and answer primer

David Block
John Harrison

FSEC-EN-5
Revised May 1997

Solar water heating is a technology that every homeowner can use to save dollars on utility bills. Questions most frequently addressed to the Florida Solar Energy Center (FSEC) about solar water heating are answered below. Please note that many replies are general and more explanation may be required for those with individual questions. For additional information, contact the FSEC Public Information Office, call a solar dealer, or consult the references listed on page 6.

Q: What is a solar water heater?

A solar water heater uses the sun's energy rather than electricity or gas to heat water, thus reducing your monthly utility bill. When installed properly, solar water heaters are more economical over the life of the system than heating water with electricity, dedicated heat pumps, heat recovery units or propane.

In Florida, three types of solar systems are used: pumped, integral collector storage (ICS), and thermosiphon. The direct circulation system (see *Figure 1, page 2*) circulates potable water from the water storage tank through one or more collectors and back into the tank. The solar collector is the main component of the solar system. It is usually a metal box with insulation and a black absorber plate that collects solar radiation and heats the water. The circulating pump is regulated by either an electronic controller, a common appliance timer, or a photovoltaic (PV) panel.

In integral collector storage systems, the solar water storage system is built into the collector. The potable water in the collector unit is heated by the sun and delivered by city or well water pressure to an auxiliary tank (which contains non-solar back-up heating) or directly to the point of use.

A thermosiphon solar water heating system has a tank mounted above the collector (normally on the roof) to provide a natural gravity flow of water. Hot water rises through piping in the collector, which is mounted below the tank; heavier cold water sinks to the lowest point in the system (the collector), displacing the lighter hot water which rises to the tank.

The ICS and thermosiphon systems are simple since they use no pumps or controllers and water always flows through the collector.

Q: How does a direct circulation solar system work?

As sunshine strikes the collector, the water inside it is heated. If the circulating pump is regulated by a PV panel, the pump starts turning as the PV panel is activated by the same sunshine. This direct current (DC) motor pump moves water from the tank through the collector and back to the tank. As the sun's intensity changes throughout the day, the circulating pump also changes its speed accordingly. By the end of the day, the water in the tank has been circulated many times through the collector and has been heated to usable hot water temperatures.

If the circulating pump is regulated by an electronic differential controller, a sensor at the outlet of the collector and a sensor at the bottom of the tank (*Figure 1*) activate the circulating pump when the water in the collector is about 15-20° F warmer than the water at the bottom of the tank. The pump then circulates water from the collector and the tank. This process continues as long as the water temperature at the collector outlet is about 5° F higher than that in the bottom of the tank. If the temperature difference decreases further, the controller automatically shuts off the pump.

Common appliance timers also may control system operation. The timer is set to operate during a period of the day when solar radiation is available to heat the potable water. It is important that the timers used in these systems incorporate battery back-up in the event of power failures. In order to avoid loss of energy from the tank during overcast days, the collector feed and return lines are both connected at the bottom of the storage tank. During normal operation, natural stratification allows the warmer water to rise to the top part of the tank.

During periods of insufficient sunshine or high hot water demand, a backup electrical element in the storage tank heats the water. The check valve prevents heat loss when the circulating pump is off. The

circulating pump consumes only a small amount of electricity — around \$5 to \$10 worth per year, or in the case of PV — none.

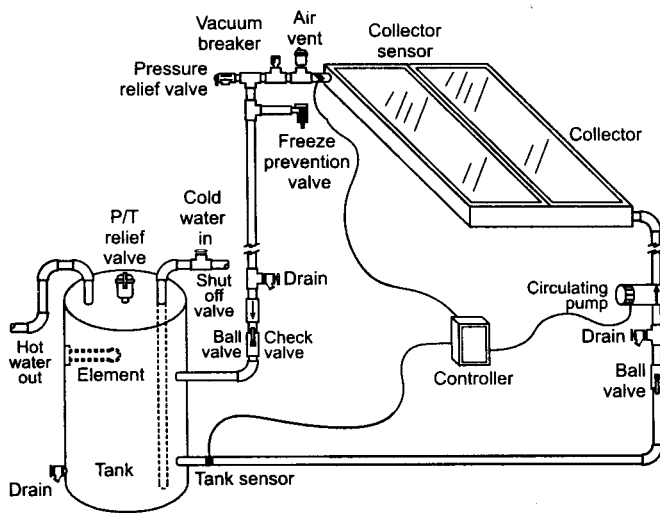

Figure 1. A solar water heating system

Q: What size solar system do I need?

For Florida residences with a dishwasher and an automatic clothes washer, a rough rule of thumb is 10-square-foot of collector area, per person, and 20 gallons of water storage, per person. Thus, for a family of four, 40-square-foot of collector and a total tank storage of 80 gallons are typical. It must be noted that ICS and thermosiphon systems will include two tanks, the solar system tank as well as the auxiliary tank.

Families can also purchase a solar-assisted system that uses a 20-to 26-square-foot collector that is retrofitted to their existing 40-or 52-gallon water heater. Due to the reduced storage tank capacity and smaller collector size, these systems will only provide 50-60% of the hot water used. The installed price will of course be lower since the existing tank and smaller collector are used.

Q: How much do I save?

Your monthly savings will depend on the amount of hot water you use, storage tank size and type and price of fuel used for backup water heating. For a family of four, the typical hot water usage is 70-gallons per day, thus using 3990-kilowatt-hours per year to heat the water electrically, or \$399 per year worth of electricity at 10¢ per kilowatt hour.

A solar water heater should save between 50% and 85% of the hot water portion of the monthly utility bill, or \$200 to \$300 per year for a family of four, if the backup element is kept at 122° F.

A solar water heater can save even more if you turn off the backup and rely solely on the sun for your hot water. During summer months, when hot water demands are lower and the sun shines longer, most solar owners turn off the backup element circuit breaker, or switch. As electricity and other fuel prices go up, solar savings will increase accordingly.

An FSEC fact sheet, *Solar Hot Water Energy and Cost Savings for Typical Florida Residential Installation*, provides an overview of the potential savings from various solar systems available in Florida.

Q: Do I have to change my habits to use a solar water heater?

No. Solar water heaters are always installed with a backup heating system in the storage tank to ensure that hot water is available at all times. However, to maximize solar utilization and your savings, you should attempt to use the most hot water in the late morning and early afternoon when the solar system is operating at its peak due to the available sunshine. Also, your solar system will be more effective if your use of hot water is spread more evenly over the week. For example, if you use hot water for laundry, instead of washing seven loads of clothes in a single day, wash one load each day. This will reduce the amount of backup energy required for your solar system.

Q: How much does a solar water heater cost?

In Florida, an installed solar water heating system can cost anywhere from \$1,500 to \$3,500. Why the large range? System cost depends upon certain variables, such as the following:

- Size of family to be served
- Size and type of solar system
- Type of financing available
- Type of roof on which the collector is to be installed
- Amount of possible utility rebate incentive
- Building code requirements
- Professional versus do-it-yourself installation.

Solar water heating is economically competitive with electrical and propane heating. It is also competitive with dedicated heat pumps and heat recovery units, depending upon the individual situation.

Q: Does government offer any financial incentives?

There are currently no federal tax credits available. In 1996, the Florida Legislature passed a state sales tax exemption for solar systems. Individuals should call their local utility company (electric or gas) about utility company rebates or incentives for solar water heating.

Q: How do I finance a solar water heating system?

The best way to finance a solar energy system is to include it as part of your home mortgage. In long-term loans of 20 years or more, the monthly solar savings will normally be greater than the monthly mortgage payments for the solar system.

If you are buying an existing home with a new mortgage, you may be able to include a new solar water heater in the mortgage. Check with your local lending office. Also, many Florida lending institutions offer short-term loans for solar systems, based upon the applicant's personal credit rating. Some solar companies also offer system financing.

Q: What kind of a solar collector should I buy?

There are basically two types of solar collectors available for solar water heating. The first is referred to as a flat-plate glazed solar collector. The second is the integral collector storage (ICS) collector (*Figure 2*). Both collectors are mounted in a fixed position throughout the year and do not track the sun as do some collectors that are used primarily for high-temperature applications.

A basic flat-plate collector consists of a metal enclosure, an absorber plate and flow tubes, insulation, and a glass covering. Flat-plate collectors can be 2 to 4 feet wide, 5 to 12 feet long, and 4 inches thick. The absorber takes in the sun's energy, which is then transferred to the water flowing through the tubes attached to the absorber.

An ICS collector consists of large tubes, often 4 inches in diameter, in which potable water is both heated and stored in a combined heat storage and collection unit. As with the flat-plate collector, the ICS unit also consists of a metal enclosure, insulation, and a glass covering. ICS units are available in

sizes ranging from 30 to 50 gallons, and can range from 4 feet in width to 8 feet in length to 10 inches in depth.

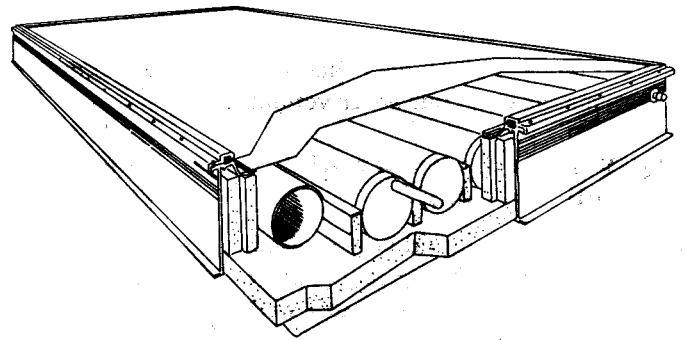

Figure 2. ICS collector

To reduce heat losses, all flat-plate and ICS collectors generally have insulation behind the absorber plate and a glass cover on the front, facing the sun. The best cover material is tempered glass of low iron content. Some edge insulation inside the enclosure box is also necessary.

The absorber plate is made of copper and is coated with a black chrome or nickel material called a selective surface. This surface greatly enhances the collector's ability to capture and retain solar energy. Some manufacturers also use black paint as an absorber coating.

The Florida Solar Energy Center conducts a state-mandated program of collector testing and certification. All collectors now sold in Florida should bear the Center's certification label.

A document entitled *Thermal Performance Ratings*, available from the FSEC Public Information office, contains the performance rating for each solar collector certified by the Center. The document also provides an approximate efficiency-per-dollar comparison method you can use as a guide for rejecting inefficient or overly expensive collectors.

Q: Since there are several different types of solar water heating systems, how can I compare their performance?

FSEC conducts a state-mandated standards program for solar domestic hot water and solar swimming pool heating systems. The same solar collector can perform differently when installed in different system types. In addition, the other components (tank, pump, controller, etc.) selected for a particular system can have a large effect on the

overall performance of a solar system. To allow comparison of complete systems, the "Florida Energy Factor" was devised to rate the performance of all solar system types. This factor is similar to the rating given to electric and gas water heaters.

The higher the energy factor, the more a solar water heater will save. The FSEC Public Information Office can supply energy factors for Florida solar systems, as can your solar vendor.

Q: What is the proper orientation of the solar collector?

Collectors should be mounted on an unshaded area of a south-facing roof. They can face up to 45 degrees east or west of south without a significant decrease in performance.

For all shingle and tile roofs in Florida that generally have pitches greater than 3 in 12 (i.e., 14 degrees), collectors should be mounted parallel to the roof. Collectors mounted in this manner are more aesthetically pleasing. However, for flat or very low-sloping roofs, collectors should be tilted at an angle (to the horizontal) that is approximately equal in degrees to the local latitude. Florida latitudes range between 25 degrees (in the Florida Keys) to 31 degrees (northern border). Since the sun is lower on the horizon during the winter months, tilting the collector at an angle up to 15 degrees greater than latitude will increase winter performance, which is desirable in most cases.

Q: Where can I buy a solar system?

Firms installing solar water heaters are listed in the telephone book or advertised in local papers. A *Florida Solar Industry Directory* and additional consumer information may be ordered from FSEC's Public Information Office.

Q: How do I decide which solar water heating dealer to contact?

Compare price, efficiency, service options, dealer reputation and warranties. Ask the solar dealer for a list of previous customers, and talk to them. Ask the owners about performance. Does the system provide sufficient hot water? Was it affected by last winter's freeze? Inquire whether service has been necessary and if it was satisfactory. Ask about the warranty offered and read it carefully. A reputable dealer/installer will normally repair or replace a system component that malfunctions in the first year if the problem is caused by faulty materials, workmanship or installation.

The quality of installation can radically affect the reliable operation of a solar system. Installers should

be licensed to install solar water heating systems. Installers should have either a state Solar Contractor or a Residential Solar Water Heating Specialty license or possess a separate license such as plumbing or air conditioning, which authorizes them to install solar residential hot water systems. Some local governments also have established a special solar contractor license.

In addition, many solar installers in the state belong to the Florida Solar Industries Association and abide by its Code of Ethics. As with other trades, your local Better Business Bureau can reveal any service or installation complaints against a vendor.

Q: How do I protect my solar system from freezing weather?

Freeze protection is an absolute must for any solar system because a single freeze can destroy a collector. Even in Miami, collector tubes have frozen and burst during hard winter freezes.

In order to avoid problems, Florida Solar Energy Center standards require that all solar systems be designed and installed with two freeze protection methods. The strategies and any instructions for the homeowner should be posted on a label affixed to a prominent location on the solar system, (usually the storage tank). There are a number of options available to prevent freeze damage to solar systems.

In the south and central Florida areas, flush-type freeze prevention valves are being used. These valves open when the air temperature approaches freezing. Water pressure forces water from the storage tank through the collectors and out through the valve. The valve closes when the water leaving the valve reaches 50° F. This process prevents the water in the collector tubes from freezing and rupturing the tubes. Though water is purged from the system and lost, only a few gallons are needed to protect the collector from freezing.

Another method of freeze protection is achieved by water recirculation. When the temperature drops below 40° F, a collector freeze sensor activates the pump to circulate warm water through the collectors. A second level of protection in this system, in the event of power failures, is provided by drain valves that manually drain the collector. Manual protection alone may be adequate for conscientious homeowners in southern Florida areas where hard freezes are rare. It is best to review the manual draindown instructions provided on the freeze information label or call your installer prior to manually draining your system.

ICS systems incorporate thermal mass freeze protection. The large size of the tanks in the ICS units requires a much longer and more severe period of freeze temperatures before all the water in the tubes

freezes. Florida freezes are generally not severe enough to turn all the water in ICS tanks into ice. Nevertheless, piping on the roof and in attics must also be protected. ICS systems in central and north Florida also incorporate a freeze prevention valve as a secondary freeze protection mechanism.

In north Florida, an indirect system is often used (Figure 3). An antifreeze solution, similar to that used in automobiles, is circulated through the collector. A heat exchanger between the collector and storage tank transfers heat from the antifreeze to the potable water. Although this system is usually more expensive and less efficient than direct systems (in which the water used for bathing, etc., is the same water circulated through the collectors), it provides better automatic freeze protection in colder climates.

In some cases, thermosiphon systems also incorporate a heat exchanger in their design, which makes the thermosiphon design quite suitable for colder climates.

Two other types of freeze protection methods — automatic drain-down and drain-back systems — are used extensively in the northern United States and are also suitable for north and central Florida. Drain-down systems normally use electrically operated valves that automatically drain the water from the collector during freezing temperatures. In drain-back systems, the collector is automatically drained whenever the circulating pump stops. With careful design and installation, both drain-down and drain-back systems can be fail-safe and cost effective.

Q: Are solar water heating systems reliable?

Properly designed and installed systems with glass-covered collectors should perform well for more than 20 years. Controllers, like other electronic devices, may require servicing during the life of the system, and the pump and hot water tank may have to be replaced after 10 years. Since conventional water heaters have the same expected lifetime, water tank replacement costs are not regarded as unique to solar energy systems.

Normal maintenance consists of checking pipe insulation, roof penetrations and collector mounting, pump operation and tank flushing. The latter is also recommended for conventional water heating systems, as is periodic replacement of the water heater sacrificial anode rod.

Many installation firms provide yearly maintenance check-ups of their solar systems similar to annual air-conditioning system maintenance programs. These can be beneficial in extending the life of the system and ensuring optimum performance.

It is important to request that the installer put an indicator on your solar system showing that the system is working. It can be as simple as a small light that comes on when the system is operating.

Q: What other ways are there to save on water heating bills?

Besides simply using less hot water, and timing solar-heated water use to peak when the solar exposure is at its peak, the following strategies are suggested:

- Wash clothes in cold or warm rather than hot water.
- Wrap extra insulation around the tank and insulate a few feet of the hot water line near the tank.
- Install an automatic timer so that the heating element comes on only during certain hours of the day. This may be cost effective if hot water is needed only for a few hours per day.

Finally, in a one-tank solar system, it's a good idea to have the back-up element controlled by a timer or manual on/off switch to keep it from coming on during the day. This strategy allows the solar system to produce all the hot water without the back-up heater being activated.

Timers may become very attractive if peak-load pricing of electricity is introduced. In that event, electricity would be priced at a much lower rate

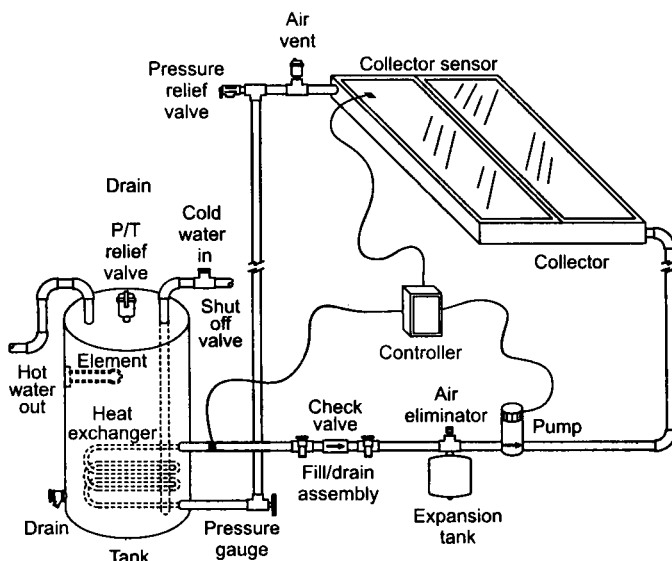

Figure 3. Indirect pumped system using antifreeze solution

during certain hours of the day than at other times. Peak-load pricing is being evaluated by many electric power companies.

Selected references:

Florida Homeowner's Manual for Energy Efficiency, FSEC-EN-20.

FSEC Approved Solar Energy Systems: Domestic Hot Water and Pool Heating, FSEC-GP-15.

Simplified Sizing Procedure For Solar Domestic Hot Water Systems, FSEC-GP-10.

Solar Domestic Hot Water Systems Repair and Maintenance Manual, FSEC-GP-34.

Solar Hot Water Energy and Cost Savings for Typical Florida Residential Installation, FSEC-GP-43

Solar Water and Pool Heating Design and Installation Manual, FSEC-IN-21.

Solar Water Heating Options in Florida, FSEC-EN-9.

Thermal Performance Ratings (FSEC Certified Solar Collectors), FSEC-GP-14 (DHW) and FSEC-GP-16 (Pool).

"Renewable Energy for Florida"



FLORIDA SOLAR ENERGY CENTER
State University System of Florida
1679 Clearlake Road, Cocoa, Florida 32922-5703, (407) 638-1000
<http://www.fsec.ucf.edu>