

1 – Junior Solar Sprint – Let’s Get Started!

If you are unfamiliar with the Junior Solar Sprint, you should preview the video and read the rules of the competition.

The Junior Solar Sprint video can be found here:

<https://vimeo.com/fsec/jss2001>

and the rules for the competition can be found here:

http://www.fsec.ucf.edu/en/education/k-12/energywhiz_olympics/jss/rules.htm



The goal of this engineering challenge is for you to design and build a race-worthy, solar-powered vehicle that can rapidly transport a ping-pong ball down a 20 meter track.

The Junior Solar Sprint competition was started by the US Department of Energy in 1991 to expose students to photovoltaics and its potential for their future. The competition challenges you to design, build and race model solar cars powered entirely by solar energy and then race your vehicle on a 20 meter track!

You will be designing and building a solar powered vehicle to compete in a 20-meter, wire guided race. The only materials you will be provided are a 3Volt solar (photovoltaic) panel and a motor. The rest you and your team will design and build.

So what do you need to know to get started? List below the questions you would like answered, the topics you would like to research to be able to build a great car, and any experts you would like to contact. For each, decide which team member is responsible for gathering the information.

1.

2.

3.

4.

5.

6.

7.

8.

Junior Solar Sprint vehicles use many different materials in their construction, many of them recycled and found materials. You will need to be thinking of items that you may already have around the house, as well as how to use common everyday items in a new way. Make a list below of items that you want to bring in to investigate and possibly use in the design of your vehicle.

As you conduct your research make notes below of the important information you learn and the source you used. You may use the internet, textbooks, magazines, books and experts in their field. Make sure to include a variety of resources. You may also download or copy printed material and highlight the relevant facts. Include your research information in this portfolio.

Internet Sites

http://www.nrel.gov/education/jss_hfc.html

National Junior Solar Sprint web site sponsored by the National Renewable Energy Laboratory

<http://www.fsec.ucf.edu/go/jss>

Florida Solar Energy Center's Junior Solar Sprint web page.

<http://fsec.zenfolio.com/ew>

Photo gallery of past year's Energy Whiz JSS entries.

<http://doolittle.icarus.com/jss/>

Larry Doolittle of Lawrence Berkeley National Laboratory has written a program that simulates a Junior Solar Sprint race based on the variables of your car.

<http://science.howstuffworks.com/178-how-solar-cars-work-video.htm>

How Stuff works video, How Solar Cars Work. Interview with captain of the University of Michigan solar car race team, describing the race car, its parts and how they work.

<http://tryengineering.org/play-games/solar-car-racing-game>

Try Engineering, solar car race game. Pick the components of your solar race car and then race it on the track.

<http://www.worldsolarchallenge.org/>

World Solar Car Challenge, annual solar car race held in Australia.

<http://americansolarchallenge.org/>

American Solar Challenge, a college level competition to design, build and race solar-powered cars across America.

www.solarcarchallenge.org/

A long distance solar car race for high school students.

<https://www.youtube.com/watch?v=OXcPFuAhvkk>

Dragon Fly TV's episode on solar cars. Kids do experiments using a Junior Solar Sprint car.

2 – Junior Solar Sprint – The Photovoltaic Panel

Your car is going to be powered by solar energy. **Photovoltaics** is the term used for the type of solar panels that turn the energy in sunlight directly into electrical energy. Since this is going to be the way you will power your race car, you will need to know how to get the most electrical energy out of your panel to power the motor. Use the investigations below to learn more about photovoltaics and what things influence the electrical output of photovoltaic panels—for good and bad.

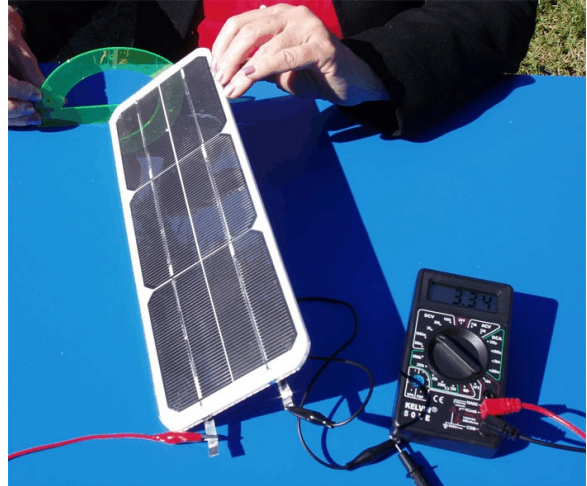

Test 1 - How do shadows affect the electrical output?

1. Attach the leads of the solar panel to an amp meter (or a multimeter set to read direct current amps) using alligator clips. Cover one of the three cells of the panel with a piece of cardboard or heavy paper. What happens to the **amperage** of the panel when you cover one of the three cells?
2. What happens if you shade $\frac{1}{2}$ of one of these cells?

Test 2 - Does it matter what angle the sunlight hits the panel?

3. Determine the angle of the sun in the sky. This is called the ‘angle of incidence’ of the sun. To do this, take a long slender object (such as a pencil) and with one end touching the ground, point the other end towards the sun. When you are pointing directly at the sun, the pointer will not cast any shadow. Then with your protractor, measure this angle and record it below and in the chart in #4.

Time of day: _____ Daylight savings time? ____ Yes ____ No

Angle of incidence _____

4. Determine if the angle of the panel has an effect on its power output. Using your protractor to measure the angle between the ground and the panel, set your panel at the angles listed in the chart below. Then record the **amperage** measurement.
Note: To get an accurate amperage reading, make sure that you’re pointed the tilted side of your panel toward the sun!

An angle of 0° would be flat on the ground. A 90° degree angle would be perpendicular to the ground

Angle of Panel	Amperage measurement
0°	
20°	
40°	
60°	
Angle of incidence as measured above _____	

- What angle produced the highest amperage reading?
- How did this compare to your angle of incidence? What conclusion can you make about which direction to point your panel to get the highest amperage output? (Hint: Think about what angle the sun's rays need to hit the panel to get the highest output)

Test 3 – Would mirrors increase the panel's electrical output?

- Will reflecting more light into the panel significantly increase the **amperage** of the panel? To find out, use aluminum foil or other shiny surface to reflect more light onto the panel. Take an amperage reading without the reflector first, then add your reflective material. Try varying the angle of the reflector to get the highest reading possible. Record your findings below.

Amperage without reflector _____

Highest amperage obtained using a reflector _____

8. What did you have to do to get your highest amperage reading?

Test 4 – Does the temperature affect the panel’s electrical output?

9. Take a **voltage** reading from your panel. (Your panel is probably fairly warm from being in the sun during the previous exercises; however, if you have just brought your panel out into the sun, give it a few minutes to warm up a bit before you take your reading.) Record the amperage below. Then take a piece of ice or a cloth dampened with ice water and gently chill the surface of the panel. Take a second reading and record below.

‘Warm’ voltage _____ ‘Chilled’ voltage _____

10. Did cooling off the panel seem to make a difference? Will this affect the way you handle your vehicle’s panel the day of the race?

Discussion and Design Decisions

With your group, discuss how you might use the findings from your investigations to help you design your Sprint vehicle. Remember, there are a lot of variables in the design of your vehicle. Each team will approach the design of their vehicles differently, with the final outcome not known until the day of the race. Your challenge is to obtain the most power you can without adding negative factors that outweigh the advantages. Here are some points to consider:

- Having the panel facing directly at the sun will increase its energy output. But how do you use that knowledge to help you design your vehicle? The position of the sun during the race is unknown until the day of the race. A solar panel that can be tilted would allow you to adjust the panel on your car the day of the race, but at what cost? A ‘tiltable’ solar panel may weigh more and cause more aerodynamic drag, slowing your car down. Is the increased power output that you may get from an adjustable tilt panel worth the drawbacks?
- A reflector could significantly increase the amount of sunlight striking your panel. However, just as with an adjustable tilt panel, a reflector will add weight and cause more aerodynamic drag. The amount of wind on race day is unknown and could have a significant effect on your vehicle. Strong crosswinds have been know to flip over

vehicles during a race. Also, what effect will reflectors have on the temperature of the panel? Commercial installations of photovoltaics seldom use reflectors because the increase in temperature lowers the efficiency of the cells. Is the increased power output that you may get from reflectors on the car worth the drawbacks?

- An easy, versatile way to attach your panel to your car is with velcro. This allows you to remove and reinstall your panel easily, and can also let several teams use the same panel.
 - Attach alligator clips to the power leads from the panel as a convenient on/off switch and a fast way to disconnect the panel.
 - How could you use the knowledge that heat negatively affects photovoltaics to help you increase the output of the panel on the day of the race?
1. Sketch several ideas in your team log. Decide as a team which idea to try first and how you will test your idea.

3 – Junior Solar Sprint – The Chassis

The chassis for your car is the underlying structure that will provide support for the motor, wheels, axles, gearing and body.

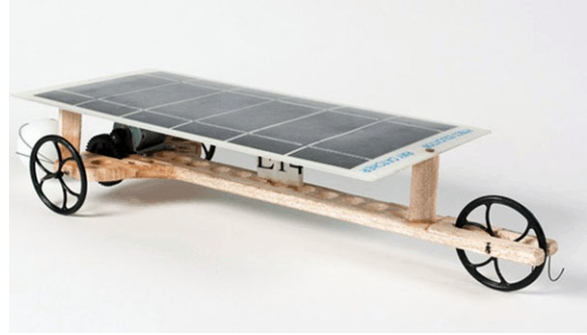

1. Make a list of the different materials that you could use for your vehicle’s chassis.

Test 1 – Weight of Materials

2. Choose six materials and write them in the top row of boxes in the table below. Weigh each piece of material and put the weight in the second row of the table. Measure the piece of material and calculate the number of square centimeters of material that was in the sample that you weighed (length in centimeters multiplied by width in centimeters). Put this value for each material in the table. Then, find the weight per square centimeter of material (divide the total weight of the material by its size in square centimeters).

Material						
Weight						
Square centimeters						
Weight per square centimeter						

3. Which material was the heaviest per square centimeter?

4. Which material was the lightest per square centimeter?
5. Why would the weight of the material you use for your chassis make a difference?

Test 2 – Strength of Materials

6. Pick three of the materials from your weight investigation that you would like to test further. Place two dowels at least 6 inches apart. (Measure this distance and make sure all your tests use this same distance) Lay a material across the dowels. (See illustration) Place weights one at a time on the material in the middle of the space between the dowels. Record how much weight (or number of weights if using something standard like coins) can be placed on each material before the material sags or breaks. To be able to determine when a material is starting to sag, use a ruler to measure the distance the material is from the table and note if this distance changes as you add weight.

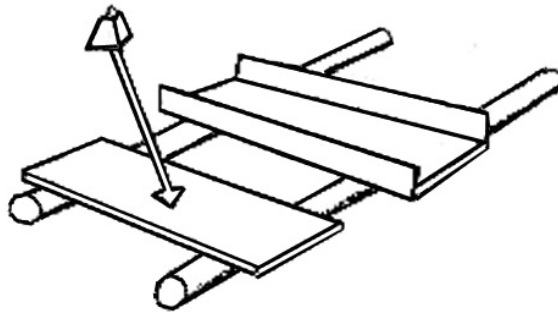

Material			
Amount of weight before sagging/breaking			

7. Which material was able to hold the most weight before it broke or began sagging?

Test 3 – Distribution of Weight

On your Sprint car the motor will probably be the heaviest thing attached to your chassis. To find out if it matters where the motor is placed, pick one of the materials from the previous investigation and place it again on the dowels. Investigate putting the weight on different areas of the material between the dowels. See if you can increase the amount of weight the material can handle before it sags.

8. If you were able to increase the amount of weight your material could hold without sagging/breaking, what area(s) did you place the weight? Draw or describe below.

9. How could you use this information to help you decide where to place your motor?

Test 4 – Stiffness and Shape of Materials

It is also possible to use flexible materials if they are constructed or shaped in ways that increase their stiffness. Engineers frequently use this technique in bridge and building design.

10. Using pieces of card stock or poster board, investigate some methods of increasing their stiffness by folding, bending or bracing the card stock material. Try three different methods, sketching your stiffening method and recording your findings in the chart below

Method of stiffening (sketch)			
Amount of weight before sagging			

11. Which method of stiffening worked best on your card stock?

Orientation

Orientation of the stiffening or bracing material is also very important.

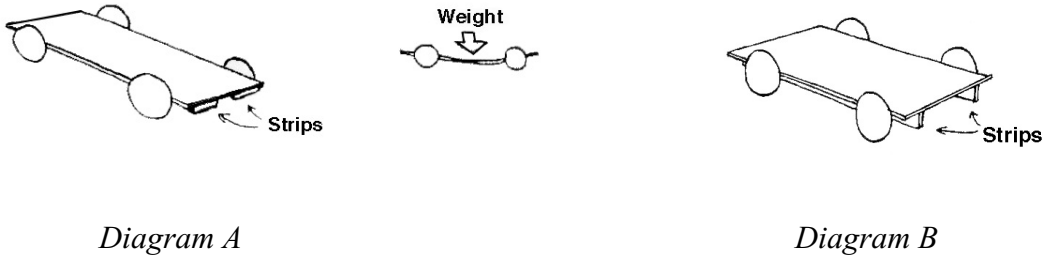

12. In the diagrams above, which method of bracing will result in the stiffer chassis – diagram A with the bracing flat in relation to the chassis, or diagram B with the bracing on edge in relation to the chassis? To find out, use a ruler to simulate the bracing and try and bend it downwards while holding it (at the ends) first flat like in diagram A, and then on edge like in diagram B. Which way was it the hardest to bend the ruler?

Composite Materials

13. Composites use two or more materials to make use of the best qualities of each. Imagine that the local cardboard manufacturer decided to sponsor the Junior Solar Sprint, and changed the rules so that each team was required to use corrugated cardboard for a main section of its chassis. Your team realizes that cardboard is lightweight, but also realizes that it is not strong enough or stiff enough for your vehicle. Describe or illustrate below, one way that you could use the cardboard in a composite design so that it would be strong enough and stiff enough to have a chance to win the race.

Discussion and Design

With your group, discuss how you might use the findings from your investigations to help you design your Sprint vehicle. Remember, there are a lot of variables in the design of your vehicle! Your goal from this investigation is to come up with a lightweight, strong and sturdy chassis that can support the systems that will be mounted to it. Here are some points to consider:

- Because it is easier for your motor to push a light car than a big heavy one, you will want your finished car to be as light as possible. But something you must also keep in mind is that a light car can be pushed easily by the wind. Even if the wind does not blow the car over, it may make it harder to go in a straight line, causing friction on the steering line which will slow your car down.
- Your car will need to be sturdy enough to withstand being handled, transported, judged, and as many as a dozen races. It is important not to sacrifice sturdiness to save weight, or your car may fall apart before the winning race!
- One frequently overlooked component of the vehicle design is the choice of glue. Glues vary in strength, weight, and ease of use. Hot glue is quick and relatively easy to use, but you may find that wood glue is stronger and lighter. Some glues will even 'eat up' or have a chemical reaction with some materials, leaving you with a hole! It is important to test your choice of glue on some scraps of material to make sure it works the way you want it to.

4 – Junior Solar Sprint – Wheels, Axles & Bearing

The purpose of the wheels is to move your vehicle as efficiently and quickly as possible. If you have not yet decided what kind of wheels you want to use on your vehicle, and how you are going to attach your wheels to your chassis, this investigation into some of the principals involved in the wheels, axles and bearings of your vehicle should give your team a place to start or a way to test your ideas.

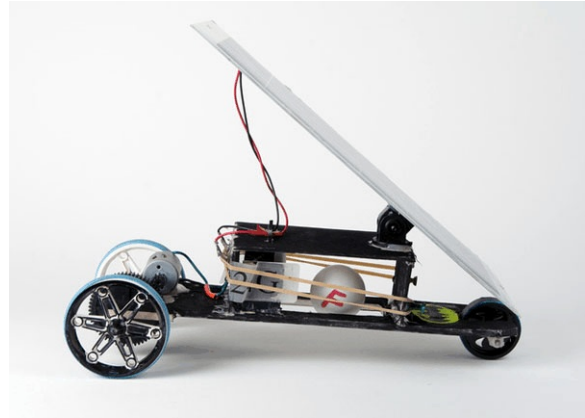

Part 1 – Wheels

1. Make a list of the different wheels that you could use. Include materials that you could make a wheel from as well as common items that could be turned into a wheel.

Weight of Material

2. Choose six materials that you would like to investigate for wheels. These could be wheels from toys or raw materials that you could use to cut out wheels. Put the name of the material (for example – small lego wheel, or balsa wood) in the top row. In the second row, put the diameter of the wheel. For the raw materials such as balsa wood, cut a circle out of the material the size of the wheel you would like to investigate. Weigh each wheel and put the weight in the third row.

Material						
Diameter						
Weight						

3. Which wheel was the lightest?

4. Why would the weight of the wheel be important?

5. Imagine that another team has decided to use a balsa wood wheel 3" in diameter. Without changing the diameter of the wheel, can you think of some ways that they could reduce the weight of the wheel?

6. Traction is important with any vehicle. Traction is the ‘gripping’ of the road by the wheels, and it is traction that enables the wheels to go forward rather than just spinning. Imagine that your group finds during the testing stage of your vehicle that your juice can lid wheels don’t have enough traction. What could you add to your wheels to increase their traction on the racing surface?

7. Weight distribution can also have an effect on traction. Imagine your group’s car from question 6 is still slipping even with the addition of ‘tires’. One of your team members suggests that you could use the weight of the motor to increase the traction. Remembering the weight distribution experiment from the previous chassis investigation, and adding what you know about traction, do you put the motor in the middle of the car, above the wheels that drive the car, or above the other set of wheels? Why?

Part 2 – Axles

8. Axles need to be stiff, strong and very straight. Make a list of the different axles that your team could use. Include materials that you could make an axle from as well as common items that could be turned into an axle (for example a bicycle spoke or an umbrella rib).

Part 3 – Bearings

Friction is very undesirable in the wheel axle. The axle must be supported and attached to the chassis, but it still must be able to spin as freely as possible. Components which allow the relative motion of the two parts are called bearings. A plain bearing can be as simple as an axle running through a hole, or it could be a bushing. A bushing is a smooth sleeve that gives the axle a low friction surface to spin in. The illustration below shows some different bearing designs.

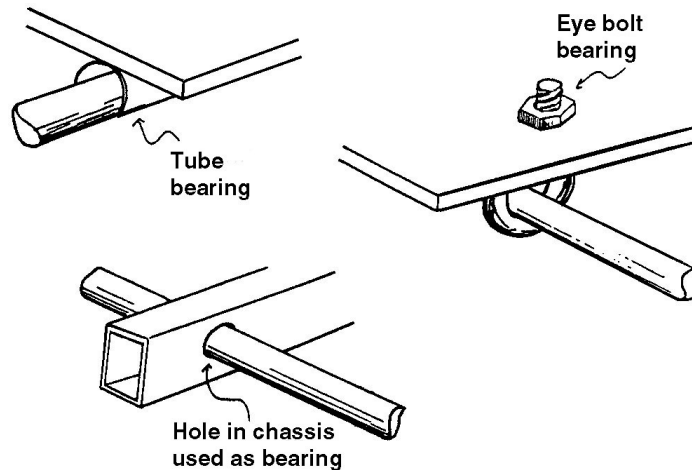

Bearing Materials

To choose the best materials for the axles and bearings you can test the friction between different types of materials. For instance, you can test the friction between metal (axle) and wood (bearing/chassis). The best bearing and axle combination will have the least amount of friction, allowing the axle to spin freely. This test will determine at what angle a sample piece of material overcomes the forces of gravity and friction and starts to slide. This test works because the weight of the object is not important. A steel paper clip will start sliding at the same angle as a heavy steel object.

- Pick three sets of materials (axle/bearing) that you would like to test and put them in the top two rows of the chart below. Balsa and steel have already been picked for you. Taking one set of materials at a time, stack one on top of the other at one end of the plank. Slowly tilt the plank by raising the end that the materials are on, until the top object starts to slide just a little. Measure the height that the plank was raised and put that number in the chart below.

Bearing Material	<i>Balsa</i>			
Axle Material	<i>Steel</i>			
Height plank was raised				

10. Which combination of materials started to slide first (at the lowest plank angle)?
11. Does this mean that those materials have more or less friction between them?
12. What would you expect to happen if you coated these two pieces with a little bit of oil or powdered graphite?

Ball Bearings

A common type of bearing is the ball bearing. The following investigation demonstrates how a ball bearing works.

13. Make sure you have the following materials for the investigation: can, lid, pencil, clay, marbles (approximately 12). Attach 1" balls of clay to both ends of a pencil. Using another 1" ball of clay, securely attach the pencil by its midpoint to the center of the lid. The two ends of the pencil should extend like paddles from the top of the lid. Place the lid on top of the soup can. Spin the lid. Does the lid seem to spin easy or hard?
14. Take the lid off the can and put about 12 marbles on top. Place the lid back on top of the can. Spin the lid. Does the lid spin easier?
15. Why do you think this is so?

Part 4 – Thrust bearings

The thrust bearing keeps the axle from falling out of the side of the car and can keep the wheel from rubbing on the body of the car.

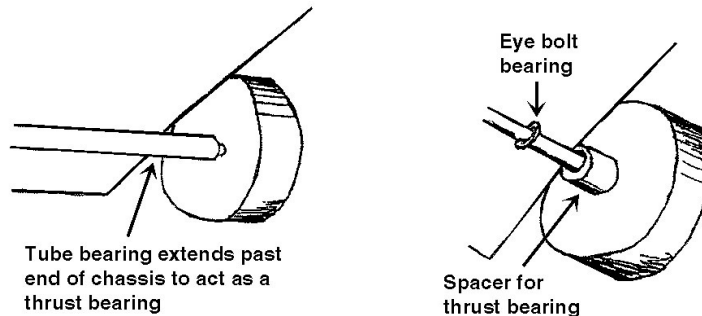

16. If there is something around the axles that let the center portion of the wheel touch first, the drag will be lower than if the outer part of the wheel touches. To demonstrate this, put a large heavy textbook flat on the table. Rotate it slowly back and forth to get a feel for how hard it is to turn. Next, put a stack of three coins on the table under the center of the book and balance the book on the coins. Make sure that the corners of the book don't touch the table and try rotating the book slowly back and forth again. Was it easier or harder to turn the book with the coins underneath?

17. Why?

18. Next, add a stack of coins under each corner and rotate the book slowly back and forth to get a feel for how hard it is to turn with a stack also on each corner. Then move the outer stacks of coins towards the center stack a little bit at a time, and test after each move (For example, try placing the coins approximately 4" apart, then 3", 2" and finally 1" apart.) Does it get easier or harder as the coins move toward the center?

Discussion and Design

With your group, discuss how you might use the findings from your investigations to help you design your Sprint vehicle. Remember, there are a lot of variables in the design of your vehicle, especially when you are designing moving parts! Your challenge here is to reduce friction on the vehicle, have enough traction on the surface, and to do it with the least amount of weight as

possible! Here are some points to also consider:

- A narrow wheel has a smaller ‘footprint’ than a wider wheel of the same diameter. This means less friction, but will you still have enough traction with the narrower wheel?
- Poor wheel alignment can waste a lot of energy. When the wheels on your vehicle are not lined up properly, some of the wheels must slide sideways, or steer your vehicle off to the side creating extra friction on the steering wire. Make sure you double check your wheel alignment. When the car is not attached to the steering wire, does it go in a straight line?
- Tires may not be necessary on your vehicle. If they are, narrow and firm tires will keep the rolling resistance (friction) low.
- The faster the axle rotates in the bearing, the more friction and drag it will have. A larger wheel will allow the axle to rotate more slowly (if the car is to go at the same speed), and will waste less power in the bearings.
- Sources of bearings could be brass or plastic tubing (drinking straws), parts from videocassettes, or screw eyes/eyebolts. Axles could be wooden rods, wire hangers, nails, and metal or plastic tubing. Remember, you want your axles and bearings to have the slickest/smoothest surface finish possible. Tires however, can be rough or rubber like to add more traction. Materials that can be used to add traction are rubber o-rings, rubber bands, cloth tape or silicone caulking. Sources of wheels (or materials to make wheels from) could be toy wheels, thin plywood, foam core, tape spool, wood dowels, balsa wood, stiff plastic sheeting, thread spool, cds, small cans, and lids.
- The axle needs to go through the absolute center of your wheel. If you make your own wheels, a compass is a great way to make sure you mark the center for your axle. Also, the wheels must be perfectly round!
- You can either design your wheel and axle assembly to be one solid unit that rotates together, or you can design your wheel to spin on your axle by using wheels that have ball bearings in the hubs. If your wheels rotate with the axle, they must be firmly attached to the axle – slippage will cause a loss in momentum. Some manufactured wheels have a slightly smaller hole than the diameter of the axle. This is known as a ‘push-fit’, and is one way of making sure the two fit very tight.
- If you choose to use a lubricant, different lubricants work better with different materials. Some appropriate lubricants for the solar car bearings may be light oil, light grease, or graphite powder. Experiment with several lubricants to find out what works best.
- Remember that the diameter of the drive wheels affect the final transmission ratio of your car – a larger wheel diameter gives a higher overall gear ratio. Gearing will be investigated in the next section.
- Test and retest your vehicle during different stages of construction. When you get your wheels attached to your chassis, check them to make sure they spin freely! You may even want to test a couple different types of wheels on a slanted board to see which rolls the easiest. Remember, it’s easier to change and modify your vehicle now than it is when it’s completely assembled.

After you assemble and attach your wheels and axles to your chassis, be sure to perform a ‘spin test’ on each of your wheels. If your wheels do not spin freely you need to figure out what the problem is and correct it before going further on your vehicle’s construction.

5 – Junior Solar Sprint – Drive Train & Transmission

The transmission in a solar car is the part that connects and transmits power from the motor shaft to the wheels or axle. In general, a transmission is any device which transmits mechanical power from one place to another. In doing so, transmissions are also used to change the speed and torque (rotational force) while transmitting the mechanical power.

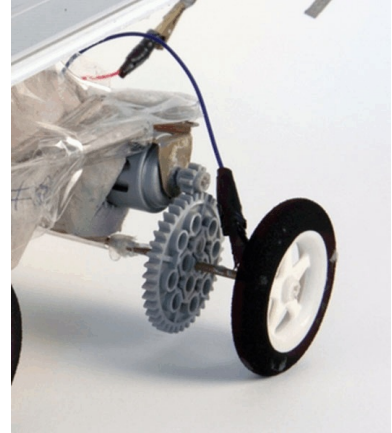

Part 1 - Direct Drive

The most simple type of transmission is direct drive, which means the motor is connected directly to the axle of the driven wheel. Direct drives are not common in vehicles; one of the few vehicles that uses direct drive is a unicycle. In the unicycle, every time your feet make one revolution, the wheel makes one revolution.

1. Attach your motor to your solar panel (or to a battery if the day is cloudy), and observe. The shaft of your motor should be spinning very fast. Grasp the motor shaft with your fingers to simulate gravity and friction. What happens? Are you able to slow down or stop the motor?
2. If you were to attach your car's drive wheel directly onto the motor shaft it would spin very fast. However, what do you think would happen when the car was placed on the ground and had to overcome the weight of the car and the friction of the surface? Would the motor be spinning as fast?
3. Would your car tend to move forward fast or slow?

Part 2 – Belt Drive

A transmission can help us overcome the problem that we observed in making a direct drive vehicle. A transmission can be a belt, friction, chain, pulley or gear drive that makes the wheels turn with higher torque (making them harder to stop), but at a slower speed than the motor shaft. Obviously, this can be a tradeoff. High speed but not enough torque and the car won't start or accelerate quickly. Low speed and high torque and the car will accelerate quickly until it reaches

its final, lower speed.

4. Make sure you have the following materials for the investigation: board with two nails in it, rubber band, large spool and small spool. Place the small spool over one nail and the larger spool over the other nail. The spools should turn freely. Slip the rubber band around both spools so when one spool is turned the other moves. Place a mark on the top edge of each spool. Watching the mark, turn the small spool (the driver wheel) 10 complete rotations. Count how many rotations the larger spool (the driven wheel) turns. How many turns did the driven wheel make?

5. When you turn the driver wheel clockwise, in which direction does the driven wheel turn?

6. Loop the rubber band over the spools in a 'figure 8' (the rubber band will cross in the area between the spools). Turn the smaller spool ten complete rotations. How many times did the large spool turn?

7. When you turn the driver wheel clockwise, in which direction does the driven wheel turn?

Part 3 – Gear Drive

For this next investigation you will be using a gear set. If you do not have a set of pre-made gears, you can make your own. You will need:

- gear template
- piece of cardboard
- glue stick or other paper glue
- (3) T-pins
- scissors
- ruler
- piece of foamboard (for base).

Glue the template to the cardboard. Carefully cut out the gears. (Note: the more accurate your cuts the better your test gears will work!). Bend the teeth of your gears halfway up (approximately 45°). Count the teeth on your gears and write the number of teeth on each gear.

8. With the ruler draw a straight line across the length of your base (or foamboard)—you will use this as a guide line to help you line up your gears. Attach two gears of the same size on your board so that the teeth mesh, and an arrow on each gear is matched up with the line on your base (if using foamboard, attach the gears with large pins). Make sure that when you turn one gear the other also turns freely. Adjust the gears position as needed. Notice that when turning the driver gear one full turn, the driven gear also turns one full turn. This is because the gears are the same size. However, when you turn the driver gear clockwise, what direction does the driven gear turn?
9. Attach the middle-sized gear for the driver and the large gear for the driven gear with a marked tooth and marked slot meshing, making new holes in the foamboard as needed. Turn the driver gear and count the rotations of each gear until the marks line up again. How many rotations did each gear make? Enter your data in the chart below.

	Number of Teeth	Number of Turns
Driver Gear		
Driven Gear		

Repeat the investigation above two more times using different combinations of gears for each trial and record your findings below.

	Number of Teeth	Number of Turns
Driver Gear		
Driven Gear		

	Number of Teeth	Number of Turns
Driver Gear		
Driven Gear		

10. What is the relationship between the two ratios for each of the trials? (Hint: reduce each ratio as far as possible) Remember: **ratio = driver gear : driven gear**
- Trial 1: Teeth to teeth ratio _____ Turn to turn (gear) ratio _____
- Trial 2: Teeth to teeth ratio _____ Turn to turn (gear) ratio _____
- Trial 3: Teeth to teeth ratio _____ Turn to turn (gear) ratio _____
11. From this data, what can you say about the relationship between the teeth ratio and the gear (turning) ratio?
12. If you had two gears with a 5:1 gear ratio and the driver gear rotates 50 times, how many times does the driven gear rotate?

From the trial above, you should also notice that the more teeth a gear has the fewer rotations it makes, and conversely, the less teeth a gear has the more rotations it makes. We lose speed in the larger gear, but we gain ‘torque’. What is torque? We use the word force to describe a pushing of something in a straight line. But, when we are trying to twist something, as in rotating gears, **the measure of turning force is called torque.**

13. Construct a gear train composed of the large and small gear. Use one finger on the smaller gear to turn the gear train and have a team member lightly touch the driven gear on the top close to the outside (near the teeth), and then increase downward pressure on the gear while it is turning. Notice how much pressure is needed to slow the gear train, and how much turning force (torque) the gear has. Repeat with the other gear being the driver. Which driven gear has more torque and is more difficult to stop?
14. For your vehicles you will want to increase the torque (force) that is at the end of your gear train (the wheels) to help your car overcome the forces of friction and gravity. Will you want the larger or the smaller gear to be your driver gear?

How does torque relate to gear ratios? The larger the diameter of a gear, the more torque it has; the smaller the diameter of a gear, the less torque it has. In fact if we could measure the torque on our gears we would find that the torque ratios are exactly the same as the gear tooth ratios.

In summary, a driver gear transmits a force at its teeth to the driven gear. This force depends on the torque supplied by the motor and the size (radius) of the gear. A driven gear transmits a torque to its axle, which depends on the force applied to its teeth and the radius of the driven gear.

But what about a vehicle's speed? Remember that there is a tradeoff. High torque which will help the vehicle overcome the forces of gravity and friction is accomplished with larger (slower turning) gears. But, low speed and high torque and the car will accelerate quickly until it reaches its top speed, which could be very slow! And conversely, high speed but not enough torque and the car won't start or accelerate quickly.

Idler Gear

15. Set up your gears in a train of three with a small gear in the middle and the two large gears on the ends. The gear in the middle is called an idler gear. Rotate the driver gear once. How many rotations does the driven gear make? Why?

16. If you turn the driver gear clockwise, what direction does the driven gear turn in?

17. What do you think the purpose of the idler gear is?

18. Try using the medium sized gear for the idler gear. Are your results the same or different?

19. Does the size of the idler gear change the output of the gear train?

Part 4 – Wheel Size

Wheel size is as important a factor in a car's design as the transmission ratio; in fact, they are closely related. In a solid axle/wheel assembly, for every revolution of the axle, the wheel makes one turn also. To measure how far your vehicle travels on each revolution of the wheels, measure the circumference of one of the drive wheels (length around the outside of the circle).

20. If you built your car with drive wheels that had a 3" circumference how far would you expect your vehicle to travel in 10 revolutions of the axle?

21. If you switched to a wheel with a 6" circumference, how far would you expect your vehicle to travel in 10 revolutions of the axle?

22. The larger wheel acts much the same way as a larger gear in a gear train does. Why wouldn't you want to put the largest wheel you could find on your vehicle? (Hint: remember torque)

Discussion and Design

With your group, discuss how you might use the findings from your investigations to help you design your Sprint vehicle. As before, remember there are a lot of variables to consider. The challenge from this investigation is to decide what type of transmission will give your vehicle the acceleration and speed needed to win the race! Here are some points to consider:

- Experiment with several different transmissions. Don't be discouraged – your first try may not work well. It helps if you build your car in such a way that you can change the gear ratios or transmission as you experiment.
- If you prefer, during this stage you can use two 1.5v batteries (equals 3V) to test your transmission.
- The speed at which the motor gives the most power is usually full speed if there is no load. As you experiment with different gear ratios, try to keep the motor turning at approximately that speed.
- The ideal gear ratio may change some if you change other characteristics of your car such as size, weight or wheel size.
- You can experiment with larger sized drive wheels by wrapping tape, foam insulation or

other materials around your wheels to run your tests.

- Mount your motor securely on a stiff part of the chassis. If the motor sags or moves, the transmission will be affected.
- Parts for your transmission may be found in old motorized toys, cassette players, and old can openers. Pulleys could be drawer pulls, videocassette reels or thread spools. Belts could be a slice of an inner tube or an o-ring. You may also purchase transmission parts from a hobby shop. Just make sure that the pitch of all your gears are the same.
- Different sun conditions may require different gear ratios. Test your vehicle in several different sun intensities. It may be that different gear ratios are best for different amounts of sunlight. You may want to be able to quickly change ratios the day of the race if the day turns out to be cloudy.

Belt/Pulley drives:

- Belts may stretch or slip off in the middle of the race. Most rubber bands are too elastic to make a good belt – use stiff rubbery materials. You may also want to design your pulleys so that it is less likely for the belt to slip off. A ‘crowned’ pulley (one with a convex or humped center) will usually solve this problem even though it seems as if the opposite would be true.
- One easy way to change the gear ratio on a pulley drive is to add or remove masking tape around a pulley, which changes its diameter.

Friction drives:

- If you use a friction drive, make sure you have enough traction on the friction disk or it will slip. However, too much tension between the motor and the drive wheel will slow the motor and your car down. The motor on a friction drive can be mounted with springs (spring loaded) so that it keeps a constant tension on the drive wheel.

Gear drives

- Make sure the gears are pressed against each other snugly to ensure traction
- Listen for the sound of gear slippage when you test your vehicle.

Just remember, if your car is not going very fast it can either be that the wheel speed is too slow, or the force required to turn the wheel is too high. Try a different gear ratio!

5 - Junior Solar Sprint – The Body

The body of your family automobile has several purposes. It protects the passengers from the weather, provides safety in the event of a crash, and it adds to the way the car looks. But it also improves the way the car performs, because a well designed body can reduce the force of the air as the car moves through it. This force, the force that the air exerts on the vehicle as it moves through it, is called aerodynamic drag or ‘wind resistance’.



Part 1 - Vehicle Size and Shape

There are two primary physical characteristics responsible for aerodynamic drag on a vehicle moving forward—the frontal area of the vehicle, and how streamlined the vehicle is.

- Using a ramp and a toy car (or your JSS vehicle with the motor and gears disconnected so that it is free rolling), release the car from the top of the ramp several times until you can observe where the car repeatedly stops. Mark this distance with a piece of masking tape. Measure the distance and enter it in the chart below.

Attach a 6 x 8" piece of foamcore or plywood with masking tape to the top of the car in the orientations listed below. In tests #2 and #3 the panel should be extending straight up from the top of the car. Run each test several times to observe where the car repeatedly stops. Mark this distance and add it to the chart below.

Test #	Orientation of board	Distance Traveled
1	No panel attached	
2	Panel perpendicular to the direction traveled (crosswise on vehicle, standing straight up)	
3	Panel parallel to the direction traveled (lengthwise on vehicle, standing straight up)	
4	Panel laying flat on the top of the vehicle (0° angle)	
5	Panel slanted back at a 30° angle	

- Did the car have less aerodynamic drag in test #2 or test #3?

3. Tests #4 and #5 could be used to simulate possible ways to attach your PV panel to your car. Did the car have less aerodynamic drag in test #4 or test #5?
4. In which test did the results come closest to test #1, where there was not any additional drag?
5. Why do you think this is so?

Place an empty soda can on two dowels, as in the diagram on the left below, so that it rests on the dowels instead of the table. Blow on the can to see how easy or hard it is to make it move.

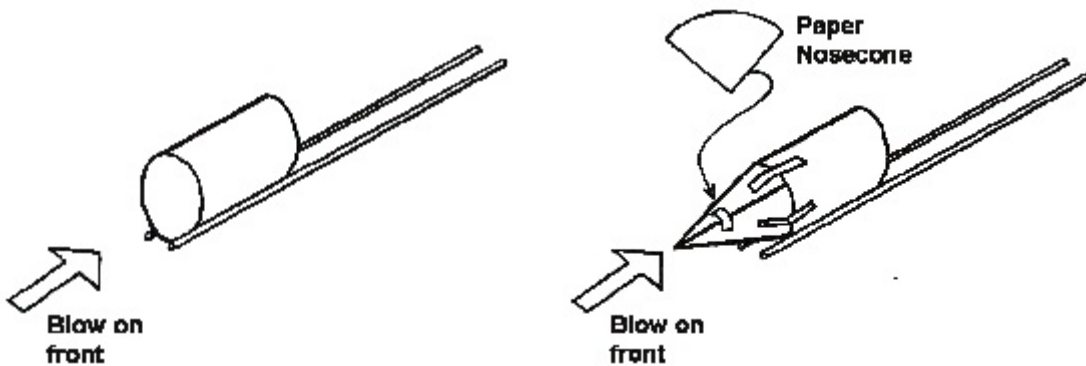

6. Make a nosecone for the can and attach it with tape. Place the can back on the dowels and blow on it. Is it easier or harder to move the can?
7. Why do you think this is so?
8. Which design would have the least aerodynamic drag if you were to use it for the front of your vehicle?

Part 2 - Wind Tunnel Testing

Wind tunnels are used frequently in the design process for automobiles, airplanes, rockets, and even bicycles. Wind tunnel experiments show which areas of the vehicle body have a streamlined efficient design, and which areas have turbulence—an increase in the amount of aerodynamic drag.

A simulated wind tunnel can be made with a box fan and a cardboard box filled with tubes to help funnel the wind in one streamlined direction. Position a platform that is large enough to hold your vehicle near the center of the box where the air will be coming out.

9. Using heavy paper, aluminum foil, shirt cardboard, thin foam, mylar, plastic sheeting, or any recycled material that you wish, construct a prototype body for your chassis. (Note: this body is for this investigation only—it does not have to be your finished design!) Sketch your prototype body below.

10. Attach strings in several places on the front of your vehicle, and also one on each side just back of the front wheels and three along the back edge of your vehicle. Place your vehicle on the platform and turn the fan on high. Observe the string. In an efficient design, the strings will float straight along the surface of the car. In a less effective design, they will flap. Describe below what you observed.

11. How would you modify your prototype to make it more aerodynamic?

Discussion and Design

With your group, discuss how you might use the findings from your investigation to help you design your Sprint vehicle. As before, remember there are a lot of variables to consider. The challenge from this investigation is to decide what type of body material and shape you want for your vehicle. As you plan, here are some things to consider:

- To be in compliance with the rules, your vehicle must have a closed body (no open wire frames) with sides large enough for a 3 centimeter square decal.
- Aerodynamic drag occurs on the underside of your vehicle also!
- Most things that move through the air use smooth, 'slick' body surfaces. This is because smooth surfaces will slip through the air, causing less turbulence, than rough surfaces. What could you do to make your vehicle's surface slicker?
- Tilting your photovoltaic panel to maximize its power output has a tradeoff. Although you will increase the power output of your panel, it will increase the vehicle's aerodynamic drag.
- Think lightweight! If attached smoothly, thin materials such as paper or cellophane can be an effective body.